

**Evolution FLUID sistem za izradu drvenih pregradnih vrata**

80kg	Dvno 30mm ÷ 45mm	650mm MIN	Meko zatvaranje
------	------------------	-----------	-----------------

PVD TS-EVOLUTION/80 mehanizam - kratki Fluid usp.

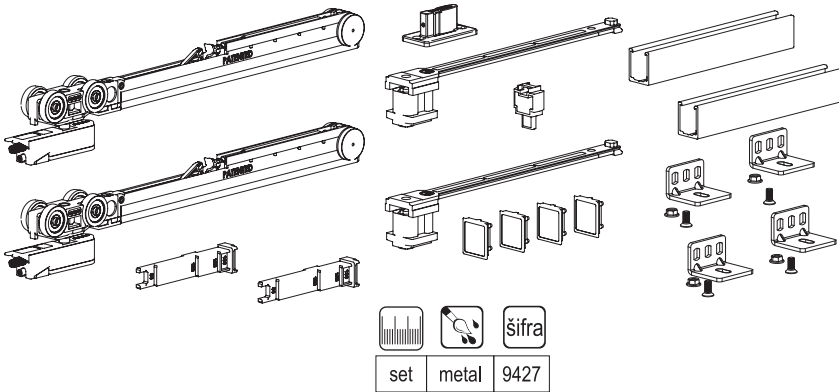

		šifra
set	metal	9427

PVD TS-1280 gornja šina AL (PVS)

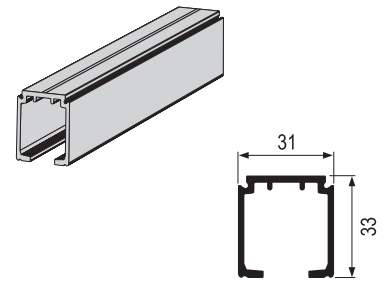

		šifra
m	SM	5748

PVD TS-1700 gornja šina AL (PVS)

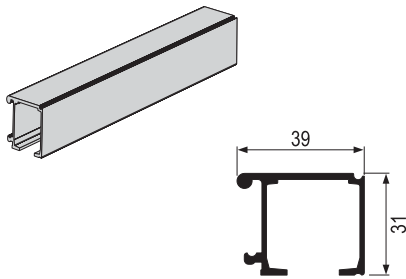

		šifra
m	SM	5756

PVD TS-1700 nosač 1720 AL (PVS)

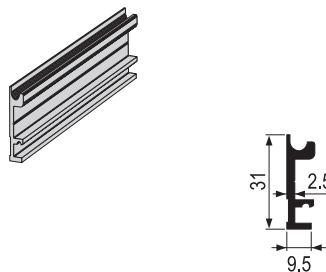

		šifra
m	SM	5757

PVD TS-1700 nosač 1710 AL (PVS)

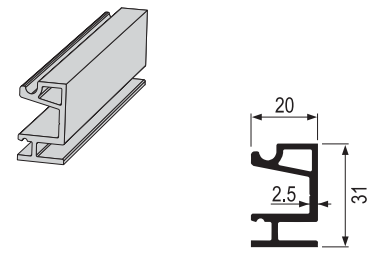

		šifra
m	SM	6256

Prodajne dimenzije profila (m): 1; 1,5; 2; 3; 4; 6.

PVD TS-1700/1280 maska AL (PVS)

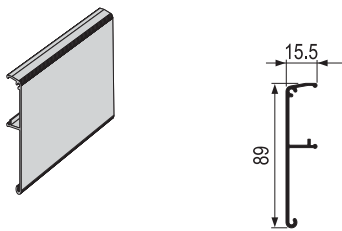

		šifra
m	SM	5760

PVD TS-1700 maska AL (PVS)

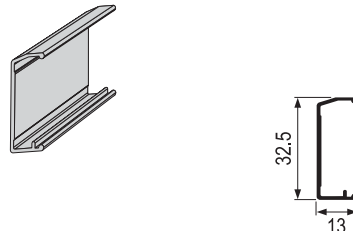

		šifra
m	SM	6243

PVD PVC donja vodica TS

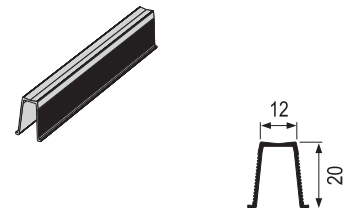

		šifra
m	siva	5764

Prodajne dimenzije profila (m): 1; 1,5; 2; 3; 4; 6.

Prodajne dimenzije profila: 1m i 3m

Tehnički crteži i prikaz montaže mehanizma

Opcije postavljanja gornjih šina i PVC dekorativni čepovi za šine

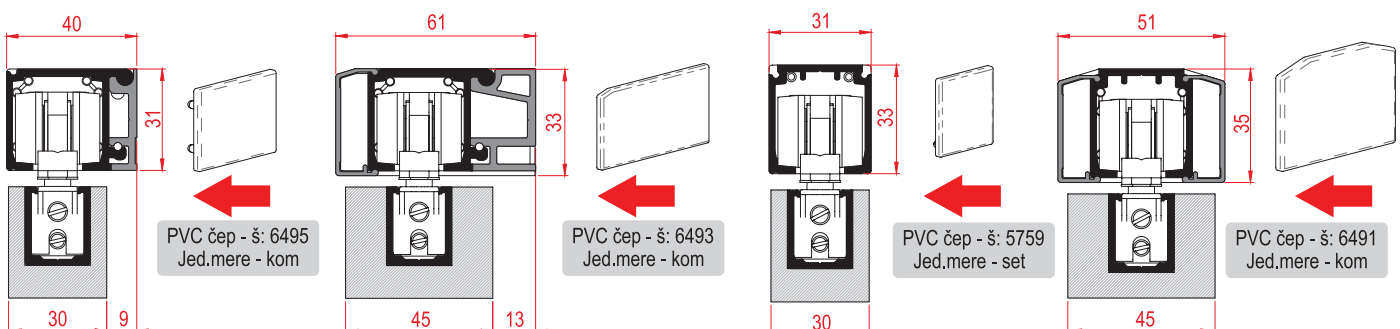

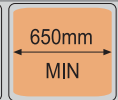
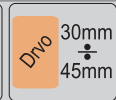

Tehnički crteži i prikaz montaže mehanizma

Prikaz pozicioniranja mehanizma u ispunu

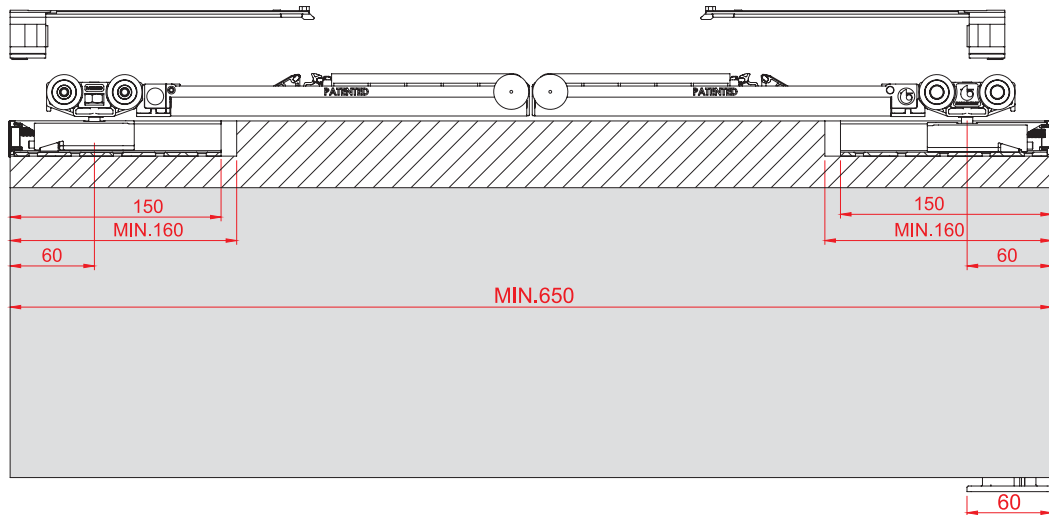

Izračunavanje visine ispunne i pozicija vrata

Priprema (ukopavanje) vrata za Evolution FLUID mehanizam

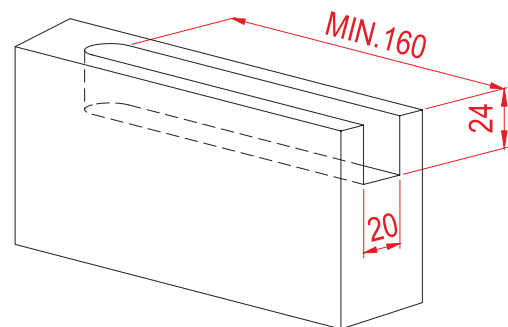
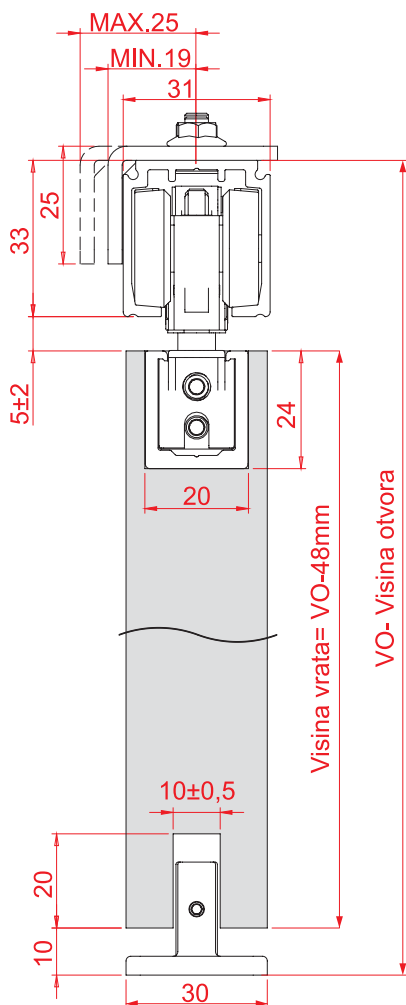

Dimenzije otvora za PVC podešavajući usmerivač pravca i PVC donju vodiču

